

# PERDURUS



PERDURUS Cast Iron Motor Series





PERDURUS is the Australian subsidiary of Huifeng Motors, leveraging more than 30 years of global manufacturing experience across Australia, Europe, and the USA. We supply IEC, NEMA, and fully customised electric motors designed to meet international standards, including IEC, CE, UL, SA, and MEPS and engineered specifically for Australian operating conditions.

The PERDURUS portfolio spans a complete range of high-demand motor constructions and technologies engineered for industrial durability, energy efficiency, and long service life. Each PERDURUS motor is designed to operate reliably across diverse applications and environments. With robust ingress protection as standard, our motors deliver dependable performance in challenging and harsh operating conditions.

With a combination of global capability, local stock, and genuine application engineering expertise, PERDURUS provides fast and tailored solutions for Australian industry. Our team brings over two decades of technical and manufacturing experience, enabling us to understand real-world challenges and deliver motors that meet stringent performance, reliability, and compliance requirements.

PERDURUS is committed to powering Australia's industries with reliable, efficient, and future-ready motor solutions.



## Perdurus Cast Iron Motors: High-Spec as Standard

Perdurus Cast Iron Motor range is purpose-built for demanding applications across Australia and New Zealand. By incorporating elite technical features as default, we provide a motor that is ready for immediate service, eliminating the need for costly options or custom modifications.

- **VSD-Ready Protection:** We eliminate the primary cause of motor failure in modern plants. Frames 280–355 include Insulated NDE Bearings and Shaft Grounding Brushes as standard to protect against VSD-induced bearing currents.
- **Maximum Protection:** IP56 ingress protection and comprehensive PTC thermal protection across the entire range.
- **Project-Ready Design:** Dual terminal boxes (Main + Auxiliary) on larger frames for clean, professional wiring and simplified thermistor termination.
- **3-Year Confidence:** A standard 36-month manufacturer's warranty, reflecting our commitment to industrial durability.

While these enhancements are often treated as premium aftermarket modifications elsewhere, PERDURUS integrates high-tier industrial features as standard. This proactive design philosophy reduces installation complexity and significantly lowers the total cost of ownership.

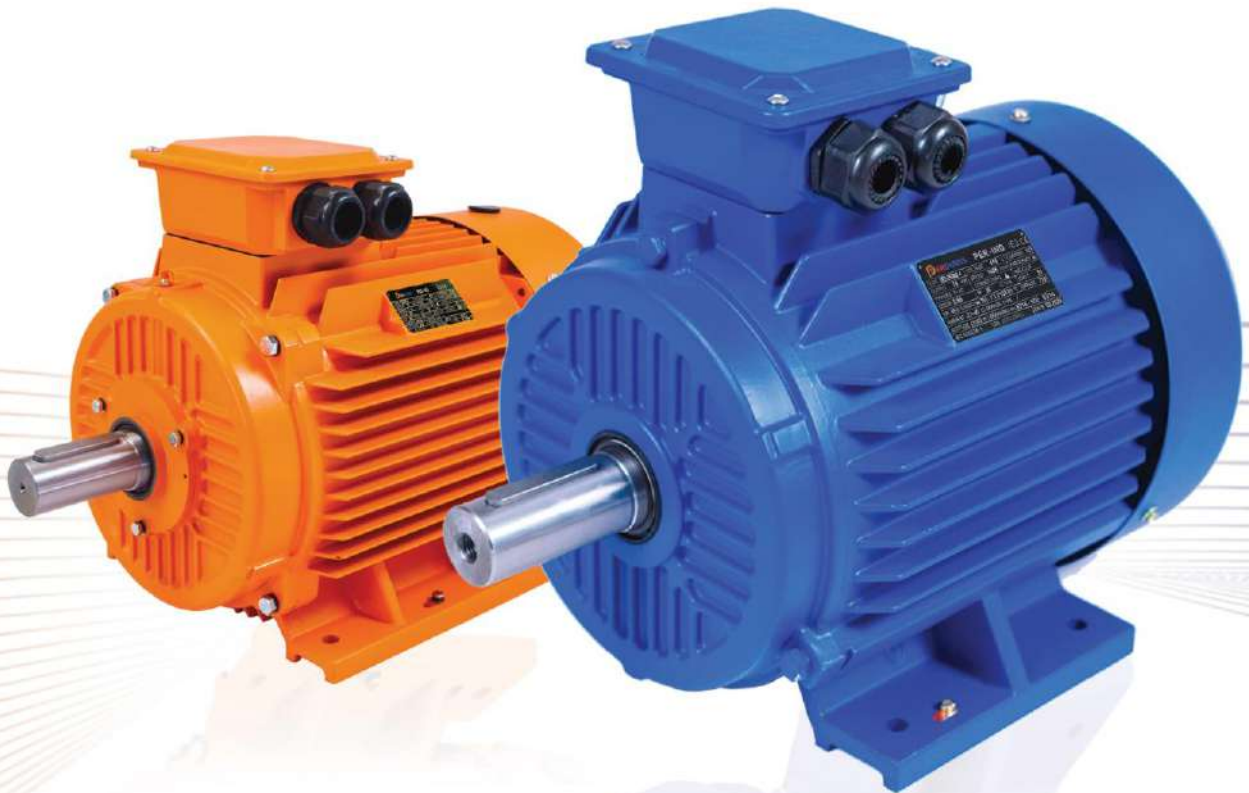

## Table of Contents

1. Technical Specification & Quality Assurance Framework	4
2. Standards & Compliance	4
3. Product Range Overview	5
4. Motor Designation & Ordering Code	6
5. Mounting Configuration	7
6. Bearings & Lubrication	7
7. Terminal Box & Cable Entry	9
8. Earthing & Electrical Safety	9
9. Cooling, Insulation & Thermal Protection	10
10. Degree of Protection (IP56)	10
11. Surface Protection & Paint System	14
12. Variable Speed Drive (VSD) Operation	15
13. Nameplates & Identification	16
14. Motor Selection Guide	17
15. Instalation, Operating Limits & Maintenance	18
16. Technical Data Sheets	19
17. Installation and Dimensions	23
18. Warranty & Scope of Supply	25



## 1. Technical Specification & Quality Assurance

Perdurus Cast Iron Motors are produced to a fixed standard industrial configuration, with defined mechanical, electrical, and protection characteristics established at the design stage. This ensures consistent suitability for industrial service, including continuous duty, inverter-driven operation, and demanding site conditions.

Manufacturing is supported by a structured quality-assurance system, with inspection and verification applied at incoming material, in-process assembly, and final testing stages. This provides consistent performance, traceability, and conformance across the PER-IND product range.

### Mechanical & Construction

- TEFC cooling system, IC411
- Shaft with standard IEC keyway and tapped end hole
- Cast-iron frame and end shields for industrial duty
- Rotor dynamically balanced to ISO 1940-1 Grade G6.3 (half-key)

### Electrical & Thermal

- VPI insulation system
- Insulation Class F with Class B temperature rise
- Standard supply: 380–415 V, 3-phase, 50 Hz
- IE3 Premium Efficiency in accordance with MEPS (GEMS)

### Protection & Environment

- IP56 protection as standard
- Drain and breather arrangement suitable for industrial environments

### Bearings & Reliability

- SKF or equivalent quality bearings
- Regreasable bearings from frame size 160 and above
- Insulated NDE bearing and shaft grounding brush as standard on frames 280–355

### Terminal Box & Installation

- Metric cable glands supplied
- Terminal box rotatable in 90° increments
- Cast-iron main terminal box, top mounted
- Internal and external earthing terminals provided

## 2. Standards & Compliance

Perdurus Cast Iron Motors are designed, manufactured, and tested in accordance with applicable Australian/New Zealand and international standards governing electrical performance, safety, efficiency, and mechanical integrity.

Category	Reference Standards
Local Compliance	AS/NZS 1359, AS/NZS 60034, MEPS/GEMS (IE3)
Electrical / Performance	IEC 60034-1, -2-1, -8, -12, -30-1
Mechanical / Protection	IEC 60034-5 (IP), -6 (IC), -7, -9, -14
Dimensions & Balance	IEC 60072-1, ISO 1940-1 (G6.3)

### 3. Product Range Overview

Perdurus Cast Iron Motors are an industrial cast-iron motor platform designed for continuous-duty applications across a broad IEC frame range.

#### Range scope

- Frame sizes: 80–355
- Duty: S1 continuous
- Frequency: 50 Hz
- Insulation: Class F standard (Class H on request)
- Poles: 2, 4, 6, and 8
- Standard supply: 380–415 V, 3-phase
- Efficiency: IE3 standard (IE4 / IE5 / IE6 on request)

#### Voltage and Connection

##### Frames 80–100

- Connections:  $\Delta$ - $\Delta$  / Y-Y // Y-Y
- Voltages: 220–240 / 380–415 V (50 Hz) // 440–460 V (60 Hz)

##### Frames 112 and above

- Connections:  $\Delta$ - $\Delta$  / Y-Y //  $\Delta$ - $\Delta$
- Voltages: 380–415 / 660–690 V (50 Hz) // 440–460 V (60 Hz)

Where higher efficiency classes or special configurations are specified, compliance is confirmed with the relevant standards.

#### Mounting availability

IEC mounting configurations including B3, B5, B35, B14, and B34, subject to frame size and configuration.

Suitable for pumps, fans, compressors, gearboxes, conveyors, and general industrial machinery.

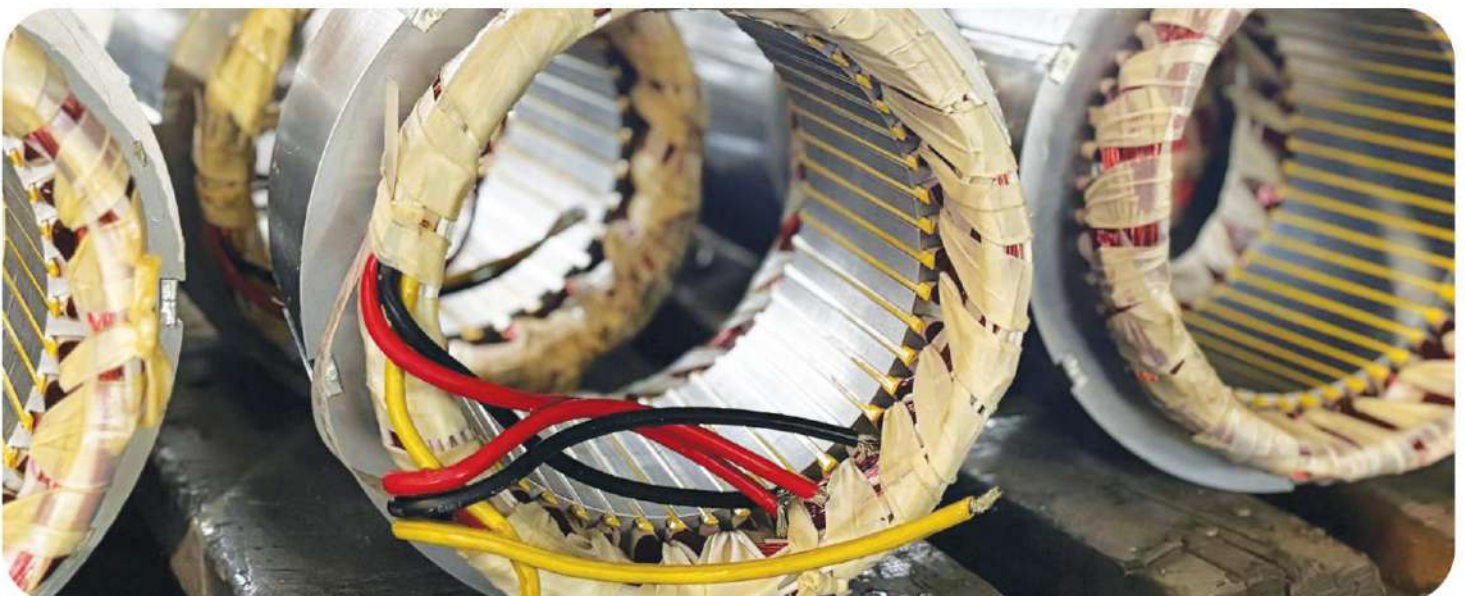

## 4. Motor Designation & Ordering Code



Each Perdurus Cast Iron Motor is identified by a structured designation used for ordering, manufacturing, and traceability.

### Standard designation:

- PER-IND – Frame – Poles
- Example: PER-IND-200L-4

### Mounting codes (IEC 60034-7):

- B3 · B5 · B35 · B14 · B34

### Optional suffixes (on request):

- IE4 / IE5 / IE6
- H (Insulation Class H)
- INB (Insulated Non Drive Bearing)
- SB (Shaft Brush)
- 2T (2 Sets of Thermistors)
- HV (High Voltage)
- SP (Space Heater)

### Complete example:

- PER-IND-315L-4-B35-IE4-H-INB-SB

All motors are supplied to the PER-IND standard build unless options are explicitly specified and confirmed.

## 5. Mounting Configuration

Foot Mounted	IM 1001 (IM B3)		IM 1051 (IM B6)		IM 1061 (IM B7)		IM 1071 (IM B8)		IM 1011 (IM V5)		IM 1031 (IM V6)	
	Horizontal shaft Foot mounted	Horizontal shaft Wall mounted, Feet on left (viewed from D.E.)	Horizontal shaft Wall mounted, Feet on right (viewed from D.E.)	Horizontal shaft Ceiling mounted, Feet above motor	Vertical shaft Wall mounted, Shaft down	Vertical shaft Wall mounted, Shaft up						
Flange Mounted	IM 3001 (IM B5)		IM 3011 (IM V1)		IM 3031 (IM V3)		IM 3601 (IM B14)		IM 3611 (IM V18)		IM 3631 (IM V19)	
	Horizontal shaft D-type flange at D.E No feet	Vertical shaft D-type flange at D.E Shaft down, No feet	Vertical shaft D-type flange at D.E Shaft up, No feet	Horizontal shaft C-type flange at D.E No feet	Vertical shaft C-type flange at D.E Shaft down, No feet	Vertical shaft C-type flange at D.E Shaft up, No feet						
Foot / Flange Mounted	IM 2001 (IM B35)		IM 2011 (IM V15)		IM 2031 (IM V36)		IM 2101 (IM B34)		IM 2111		IM 2131	
	Horizontal shaft D-type flange at D.E Foot mounted	Vertical shaft D-type flange at D.E Shaft down, Wall mounted	Vertical shaft D-type flange at D.E Shaft up, Wall mounted	Horizontal shaft C-type flange at D.E Foot mounted	Vertical shaft C-type flange at D.E Shaft down, Wall mounted	Vertical shaft C-type flange at D.E Shaft up, Wall mounted						

## 6. Bearings & Lubrication



Perdurus Cast Iron Motors are equipped with rolling element bearings selected for industrial continuous-duty operation and variable speed drive compatibility.

### Factory-Filled Grease (Standard):

Motors are factory-filled with high-temperature EP composite lithium grease, NLGI Grade 2.

### Australian equivalent greases (do not mix greases without purging):

SKF LGHP 2 · Shell Gadus S3 V220C 2 · Mobilith SHC 100 · Castrol Spherol EPL 2 · Fuchs Renolit LX-EP 2

## Bearing Configuration & Re-Greasing Interval

Frame Size	Drive End (DE) Bearing	Non-Drive End (NDE) Bearing	VSD Bearing Protection	Lubrication Method	Re-Grease Interval*
80–132	Deep groove ball	Deep groove ball	—	Sealed / life-lubricated	Not required
160–250	Deep groove ball	Deep groove ball	—	Grease nipple provided	Every 4,000 h
280–355	Deep groove ball (NU roller DE available on request)	Insulated deep groove ball	Insulated NDE + shaft grounding brush (std.)	Grease nipple provided	Every 2,000–3,000 h

IEC Frame	Bearings	
	D.E.	N.D.E.
PID-132S	6208	6208
PID-132M	6208	6208
PID-160M	6309	6309
PID-160L	6309	6309
PID-180M	6311	6311
PID-180L	6311	6311
PID-200M/L	6312	6312
PID-225S/M-2	6313	6313
PID-225S/M-4,6,8	6313	6313
PID-250S/M-2	6316	6314
PID-250S/M2-2	6316	6314
PID-250S/M-4,6,8	6316	6314
PID-250S/M2-4	6316	6314
PID-280S/M-2	6317	6314
PID-280S/M2-2	6317	6314
PID-280S/M-4,6,8	6317	6317
PID-280S/M2-4	6317	6317
PID-315S/M/L-2	6317	6317
PID-315S/M/L-4,6,8	6319	6319
PID-355M/L-2	6319	6319
PID-355M/L-4,6,8	6322	6322

- Normal operating conditions: S1 duty, ≤40 °C ambient, clean environment.

### Note

- Grease nipples are provided as standard from frame size 160 and above.
- Deep groove ball bearings are supplied as standard unless otherwise specified.
- For frame sizes up to 250, additional bearing protection for VSD compatibility is generally not required, in line with IEC guidance and PERDURUS recommendations.

## 7. Terminal Box & Cable Entry



Perdurus Cast Iron Motors are supplied with a robust terminal box arrangement designed for industrial environments.

- Main terminal box manufactured from cast iron
- Top-mounted as standard, rotatable in 90° increments
- Sealing designed to maintain IP56 protection

### Cable Gland Configuration & Sizes

Frame Size	Number of Holes	Hole Size (Metric)
63 – 71	1 × M20 × 1.5	M20
80 – 100	1 × M20 × 1.5	M20
112 – 132	2 × M25 × 1.5	M25
160 – 180	2 × M40 × 1.5	M40
200 – 225	2 × M50 × 1.5	M50
250 – 280	2 × M63 × 1.5	M63
315 – 355	2 × M63 × 1.5	M63

### Note

- Terminal box allows 90° rotational positioning.
- Alternative hole quantities and thread sizes are available on request.
- All glands and accessories must match or exceed IP56 rating.

### Auxiliary Terminal Box

- Frames 280 and above supplied as standard with auxiliary terminal box
- Two sets of thermistors provided (alarm and trip)

## 8. Earthing & Electrical Safety

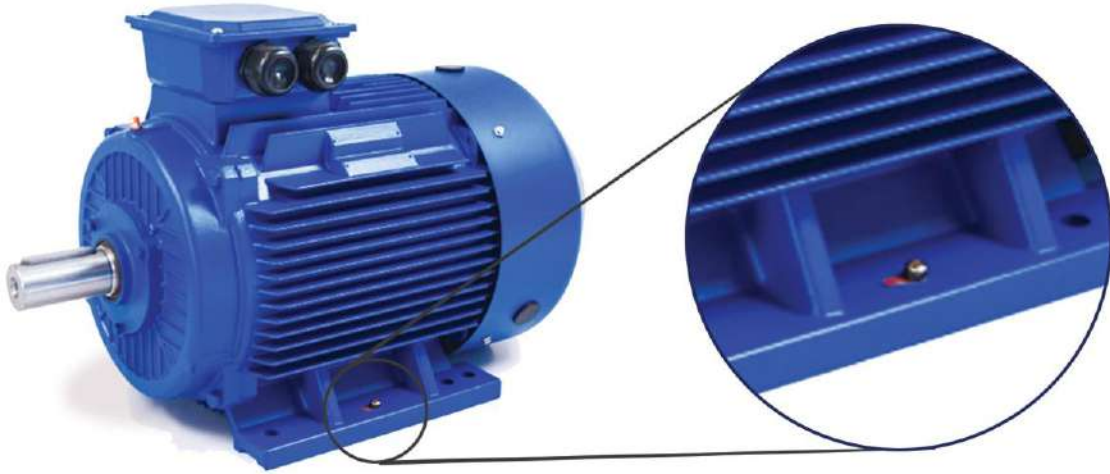

Perdurus Cast Iron Motors feature specified earthing arrangements to guarantee electrical safety and compliance with standards.

- Internal earth terminal provided inside the main terminal box
- External earth terminal provided on the motor frame
- Earthing must comply with applicable AS/NZS and IEC standards

Correct earthing is mandatory prior to energising the motor.

## 9. Cooling, Insulation & Thermal Protection

---

Perdurus Cast Iron Motors feature a controlled thermal system that enables continuous-duty operation, long-lasting insulation, and dependable performance in direct-on-line and inverter-fed configurations.



## Cooling System

- Designed for S1 continuous duty
- Cooling method: IC411 (IEC 60034-6)
- Totally Enclosed Fan-Cooled

## Insulation System

- Insulation Class H available on request
- Insulation Class F supplied as standard
- VPI Impregnation: Boosts dielectric strength, mechanical rigidity, and thermal cycling durability

## Temperature Rise Philosophy

Perdurus Cast Iron Motors are designed with Class F insulation and operate at a Class B temperature rise under rated conditions. This approach reduces thermal stress on the windings, extends insulation service life, and enhances tolerance to overloads and VSD operation.

The relationship between insulation class, permissible temperature rise, and thermal margin is illustrated in the insulation class and temperature rise chart included in this catalogue (IEC reference conditions, 40°C ambient).

## IEC Thermal Limits (Reference)

- Class B: 130 °C
- Class F: 155 °C
- Class H: 180 °C

Operating Class F insulation at Class B temperature rise provides a thermal safety margin, reducing insulation ageing in industrial service.

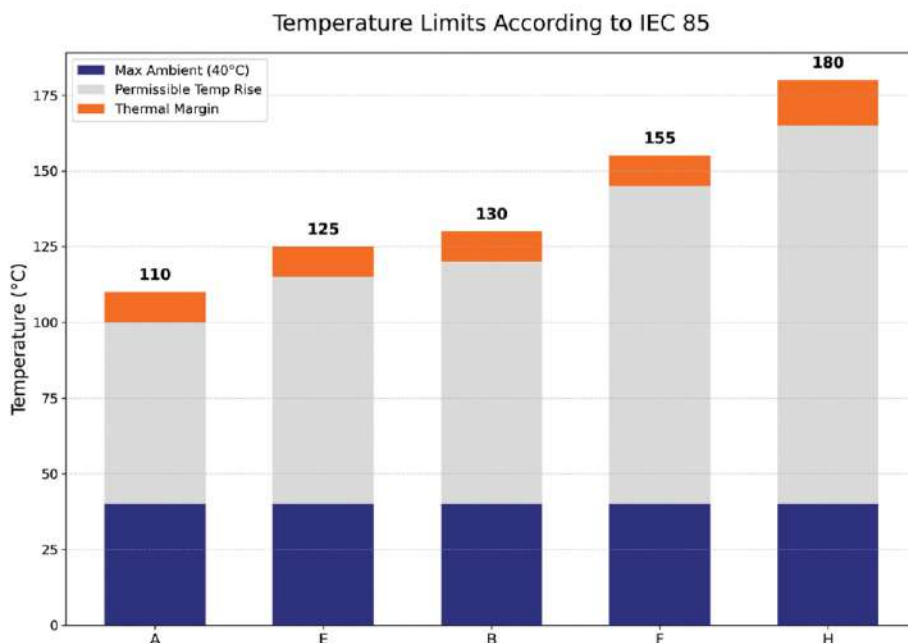

## Thermal Protection

Perdurus Cast Iron Motors are equipped with PTC thermistors for stator temperature protection.

**Frame sizes 132–250:**

- One set of PTC thermistors supplied as standard, intended for over-temperature protection

**Frame sizes 280 and above:**

- Two sets of PTC thermistors supplied as standard: – One set for alarm/– One set for trip

For frame sizes 280,315 & 355, an auxiliary terminal box is supplied as standard, incorporating a dedicated terminal block for thermistor connections.

## Standard Ambient Conditions & Insulation Requirements

Unless stated otherwise, all rated outputs shown in this catalogue correspond to continuous duty S1, in accordance with IEC 60034-1, under the following standard operating conditions:

- Ambient temperature:  $-20\text{ }^{\circ}\text{C}$  to  $+40\text{ }^{\circ}\text{C}$
- Installation altitude: Up to 1000 m above sea level
- Environmental condition: Non-condensing, standard industrial environments

In very humid or condensation-prone environments, the use of a space heater is recommended to minimise the risk of internal moisture accumulation during standstill conditions.

For operation outside these standard conditions, applicable derating factors must be applied to determine the maximum permissible output power ( $P_{\text{max}}$ ).



## 10. Degree of Protection (IP56)



The ingress protection rating defines protection against solid objects and liquids in accordance with IEC 60529.

Perdurus Cast Iron Motors are supplied with IP56 protection as standard.

- First digit 5: Dust-limited ingress with no harmful deposits
- Second digit 6: Protection against powerful water jets from all directions

This level of protection is suitable for typical industrial and outdoor environments.

INGRESS PROTECTION (IP) RATINGS			
FIRST NUMBER	PROTECTION AGAINST SOLIDS	SECOND NUMBER	PROTECTION AGAINST LIQUIDS
0	No protection	0	No protection
1	Objects over 50 mm (hand)	1	Vertically falling drops of water
2	Objects over 12 mm (finger)	2	Direct sprays up to 15° from vertical
3	Objects over 2.5 mm (tools and wires)	3	Direct sprays up to 60° from vertical
4	Objects over 1 mm (small tools and wires)	4	Sprays from all directions, limited ingress
5	Dust-limited ingress (no harmful deposit)	5	Low pressure jets of water from all directions, limited ingress
6	Totally protected against dust	6	Strong jets of water from all directions, limited ingress
		7	Temporary immersion (30 minutes) between 15 centimeters and 1 meter
		8	Long periods of immersion under pressure

## 11. Surface Protection & Paint System

PERDURUS Cast Iron Motors are finished with a high-performance industrial coating system.

- Standard colour: RAL 5005 (IE3 series)
- Three layer coating system
  - Epoxy primer: 30–40 µm
  - Intermediate epoxy or enamel: 30–40 µm
  - Polyurethane (PU) topcoat: 40–50 µm
- Minimum total dry film thickness (DFT): approx. 150 µm

All motors are painted using a controlled, high-quality industrial paint booth.

Alternative paint systems and colours are available on request.



## 12. Variable Speed Drive (VSD) Operation

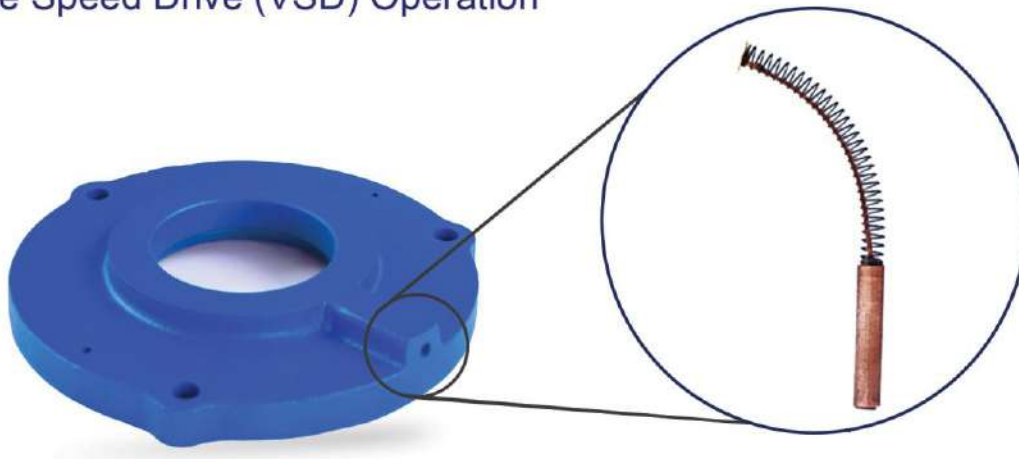

Perdurus Cast Iron Motors are suitable for operation on PWM variable speed drives. In line with IEC 60034-17 guidance for inverter-fed machines, the available continuous torque under self-ventilated (TEFC) cooling is frequency-dependent and limited by permissible temperature rise. The adjacent curve shows the measured/validated continuous torque capability versus frequency without forced ventilation, including low-speed thermal derating and the field-weakening region above base frequency.

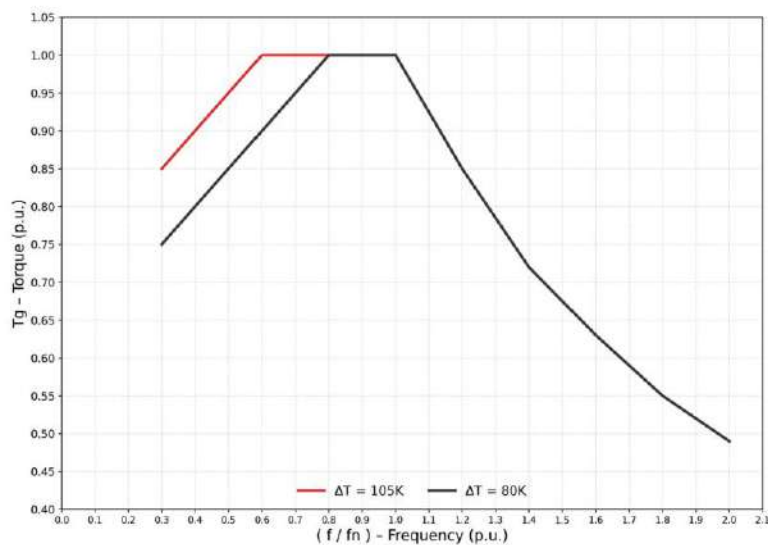

### Bearing Current Mitigation (VSD Duty)

For IEC frame sizes 280 and above, Perdurus Cast Iron Motors are supplied as standard with:

- Insulated non-drive-end (NDE) bearing, and
- Shaft grounding brush fitted at the drive end (DE) new pattern

to reduce the risk of VSD-induced bearing currents, consistent with the intent of IEC 60034-25.

For frame sizes below 280, additional bearing protection is typically not required when the drive system is correctly installed and earthed; however, suitability depends on the specific VSD, cabling and installation conditions

### 13. Nameplates & Identification

All Perdurus Cast Iron Motors are fitted with permanent nameplates to ensure clear identification, traceability, and compliance throughout the motor service life.

#### Nameplate Construction

- AISI 304 stainless steel
- Laser-etched for permanent legibility
- Riveted securely to the motor frame

All nameplate data complies with IEC 60034-1 and matches the PERDURUS order specification exactly.

#### Main Motor Nameplate (All Frames)

Each motor includes, at minimum:

- Frame size
- Power factor (PF)
- Full-load current (A)
- Bearing types (DE / NDE)
- PER-IND model designation
- Serial number and manufacture date
- Efficiency class IE3 (100% / 75% / 50%)
- Speed (r/min)
- Rated power (kW)
- Voltage and frequency
- Degree of protection IP56
- Grease type (where applicable)
- PTC thermistor data (where applicable)
- Insulation Class F with Class B temperature rise

		<b>PER-IND</b>	<b>IE3 CE</b>
TYPE <b>YE3-200L-4</b>	VOLTAGE <b>415 V</b>	CURRENT <b>51.8 A</b>	
OUTPUT <b>30 kW</b>	SPEED <b>1475 r/min</b>	FREQUENCY <b>50Hz</b>	
PHASES <b>3~AC</b>	CONNECTION <b>Δ</b>	INS.CL. <b>F</b>	
COS Φ <b>0.86</b>	IP <b>56</b>	IC411	DUTY <b>S1</b>
EFF. <b>93.6 % (100%) 92.9 % (75%) 92.3 % (50%)</b>	WEIGHT <b>264 kg</b>		
AMBIENT <b>-20~40 °C</b>	GREASE TYPE <b>/</b>		
ALTITUDE <b>≤1000 m</b>	BEARINGS DE <b>6312</b> / NDE <b>6312</b>		
IEC 60034-1	SN. <b>20260208003</b>	DATE <b>02.2026</b>	

#### Auxiliary Nameplate (Frames 280–355)

For frame sizes 280 to 355, an auxiliary nameplate is provided where required to identify dual PTC thermistor configuration, insulated bearing and shaft grounding features, and special executions (INB, SB, 2T, GN).

<b>PTC THERMISTORS</b>		<b>TM 95300</b>
Trip Temperature	<b>140 °C</b>	<b>DO NOT</b>
Alarm Temperature	<b>130 °C</b>	<b>MEGGER</b>
NDE Bearing: Insulated Bearing		
DE Bearing: Shaft Grounding Brush		

## 14. Motor Selection Guide

Correct motor selection ensures required performance, efficiency, and service life. This guide provides a quick reference followed by essential engineering relationships.

### Engineering Formulas

Three-phase input power:

- $P_{in} \text{ (kW)} = \sqrt{3} \times V \times I \times PF / 1000$

Output power:

- $P_{out} = P_{in} \times \eta$

Torque:

- $T \text{ (Nm)} = 9550 \times P_{out} \text{ (kW)} / n \text{ (r/min)}$

Synchronous speed:

- $n_s = 120 \times f / p$

Rated motor speed accounts for slip and is stated on the nameplate.

### Motor Selection Parameters – Critical

Parameter	Key Considerations	Why it's Important
Power Output (kW / HP)	Required Load Startup Torque Application Type	Ensures Motor Meets Demand Without Oversizing
Voltage & Frequency	Supply Voltage (e.g. 240V / 415V) Frequency (50Hz / 60Hz)	Prevents Compatibility Issues & Overheating
Speed / No. of Poles	2-Pole ≈ 3000 rpm 4-Pole ≈ 1500 rpm 6-Pole ≈ 1000 rpm	Matches Motor Speed With Process Requirements
Mounting Arrangement	B3 / B5 / B14 B35 / B34	Ensures Correct Installation and Alignment
IP Rating & Environmental	IP44 (Indoor) IP55 (Industrial) IP66 (Dust/Water Protection)	Guides Enclosure Protection & Material Choice

Parameter	Key Considerations	Why it's Important
Insulation Class & Ambient	Class F/H Temperature Rise - Ambient Operating Temp	Impacts Thermal Limits, Reliability & Lifespan
Efficiency & Duty Cycle	IE rating (IE3–IE6) Continuous / Intermittent Duty	Reduces Energy Cost & Affects Lifespan
Starting Method	DOL or Star-Delta VSD or Soft Starter	Affects Inrush Current & Torque
Cooling Method (IC Code)	IC410 -TENV (Totally Enclosed Non-Ventilated) IC411 - TEFC (Totally Enclosed Fan Cooled) IC416 – Forced Ventilation	Ensures Adequate Cooling in Demanding Applications
Bearings & Lubrication	Bearing Type Regreasing Intervals	Critical for Noise, Vibration & Reliability

## 15. INSTALLATION, OPERATING LIMITS & MAINTENANCE

Installation and commissioning of Perdurus Cast Iron Motors shall be performed by appropriately qualified personnel, in accordance with applicable IEC and AS/NZS standards, statutory requirements, and site safety procedures. Detailed installation and commissioning instructions are provided in the PERDURUS Installation & Maintenance Manual, supplied separately.

Perdurus Cast Iron Motors shall be operated within the limits specified on the motor nameplate and in this catalogue. Motors are rated for S1 continuous duty unless otherwise stated. Operation outside standard ambient temperature, altitude, or supply conditions shall be subject to derating and engineering assessment. Motors are not suitable for use in hazardous or explosive atmospheres unless specifically certified for such applications.

Perdurus Cast Iron Motors are designed for long-term industrial service when maintained in accordance with recommended practices by qualified personnel. Maintenance activities shall not adversely affect alignment, ingress protection, or bearing integrity. Detailed maintenance requirements are provided in the PERDURUS Installation & Maintenance Manual, supplied separately.

16. Technical Data Sheets

IEC frame	Output (kW)	Rated Speed (rpm)	Full load current I <sub>R</sub> (A)	Locked rotor current (I <sub>L</sub> /I <sub>R</sub> )	Full load torque T <sub>R</sub> (N.m)	Locked rotor torque (T <sub>L</sub> /T <sub>R</sub> )	Break-down torque (T <sub>B</sub> /T <sub>R</sub> )	415V						Sound power level dB(A)
								% of full load						
								Efficiency η (%)			Power factor (cosφ)			
								50	75	100	50	75	100	
<b>2 Pole-3000 rpm-50Hz</b>														
PID-132S1-2	5.5	2935	9.7	8.5	17.9	2.0	2.3	87.5	89.2	89.2	0.75	0.85	0.88	79
PID-132S2-2	7.5	2935	13.2	8.5	24.4	2.0	2.3	89.2	90.2	90.1	0.75	0.85	0.88	79
PID-160M1-2	11	2955	18.9	8.5	35.5	2.0	2.3	89.7	91.1	91.2	0.78	0.86	0.89	81
PID-160M2-2	15	2955	25.5	8.5	48.5	2.0	2.3	91.1	91.8	91.9	0.79	0.86	0.89	81
PID-160L-2	18.5	2955	31.3	8.5	59.8	2.0	2.3	91.8	92.3	92.4	0.82	0.88	0.89	81
PID-180M-2	22	2965	37.1	8.5	70.9	2.0	2.3	91.6	92.4	92.7	0.82	0.88	0.89	83
PID-200L1-2	30	2965	50.3	8.5	96.6	2.0	2.3	93.0	93.2	93.3	0.77	0.85	0.89	84
PID-200L2-2	37	2965	61.7	8.5	119	2.0	2.3	93.4	93.7	93.7	0.78	0.86	0.89	84
PID-225M-2	45	2965	74.0	8.0	145	2.0	2.3	92.8	93.7	94.0	0.84	0.90	0.90	86
PID-250M-2	55	2970	90.2	8.0	177	2.0	2.3	92.9	93.9	94.3	0.82	0.88	0.90	89
PID-280S-2	75	2970	122	7.5	241	1.8	2.3	93.1	94.3	94.7	0.85	0.90	0.90	91
PID-280M-2	90	2970	146	7.5	289	1.8	2.3	93.5	94.6	95.0	0.87	0.90	0.90	91
PID-315S-2	110	2975	179	7.5	353	1.8	2.3	93.0	94.5	95.2	0.84	0.89	0.90	92
PID-315M-2	132	2975	214	7.5	424	1.8	2.3	93.1	94.6	95.4	0.86	0.90	0.90	92
PID-315L1-2	160	2975	256	7.5	514	1.8	2.3	93.5	94.8	95.6	0.87	0.91	0.91	92
PID-315L2-2	200	2975	319	7.5	642	1.8	2.2	93.9	95.3	95.8	0.86	0.90	0.91	92
PID-355M-2	250	2980	399	7.5	801	1.6	2.2	93.7	95.2	95.8	0.87	0.91	0.91	100
PID-355L-2	315	2980	503	7.5	1009	1.6	2.2	93.7	95.3	95.8	0.86	0.90	0.91	100
<b>High-Output Design - Special Frame</b>														
PID-250M2-2	75	2970	122	7.5	241	1.8	2.3	93.1	94.3	94.7	0.78	0.87	0.90	89
PID-280M2-2	110	2970	179	7.5	354	1.8	2.3	93.8	94.8	95.2	0.79	0.88	0.90	91

IEC frame	Output (kW)	Rated Speed (rpm)	Full load current I <sub>R</sub> (A)	Locked rotor current (I <sub>L</sub> /I <sub>R</sub> )	Full load torque T <sub>R</sub> (N.m)	Locked rotor torque (T <sub>L</sub> /T <sub>R</sub> )	Break-down torque (T <sub>B</sub> /T <sub>R</sub> )	415V						Sound power level dB(A)
								% of full load						
								Efficiency η (%)			Power factor (cosφ)			
								50	75	100	50	75	100	
<b>4 Pole-1500 rpm-50Hz</b>														
PID-132S-4	5.5	1460	10.3	7.9	36.0	2.0	2.3	88.3	89.2	89.6	0.61	0.74	0.83	71
PID-132M-4	7.5	1460	13.7	7.5	49.1	2.0	2.3	89.1	90.1	90.4	0.63	0.76	0.84	71
PID-160M-4	11	1465	19.7	7.7	71.7	2.2	2.3	89.6	90.6	91.4	0.67	0.78	0.85	73
PID-160L-4	15	1465	26.3	7.8	97.8	2.2	2.3	91.4	91.8	92.1	0.69	0.79	0.86	73
PID-180M-4	18.5	1475	32.3	7.8	120	2.0	2.3	91.6	92.5	92.6	0.70	0.80	0.86	76
PID-180L-4	22	1475	38.3	7.8	142	2.0	2.3	92.0	92.8	93.0	0.70	0.80	0.86	76
PID-200L-4	30	1475	51.8	7.3	194	2.0	2.3	92.3	92.9	93.6	0.73	0.83	0.86	76
PID-225S-4	37	1480	63.7	7.4	239	2.0	2.3	92.1	93.0	93.9	0.75	0.84	0.86	78
PID-225M-4	45	1480	77.3	7.4	290	2.0	2.3	93.4	93.8	94.2	0.77	0.85	0.86	78
PID-250M-4	55	1485	94.1	7.4	354	2.2	2.3	93.4	94.2	94.6	0.76	0.84	0.86	79
PID-280S-4	75	1485	125	6.9	482	2.0	2.3	94.0	94.7	95.0	0.82	0.87	0.88	80
PID-280M-4	90	1485	149	6.9	579	2.0	2.3	93.8	94.7	95.2	0.82	0.88	0.88	80
PID-315S-4	110	1485	180	7.0	707	2.0	2.2	94.0	95.1	95.4	0.80	0.86	0.89	88
PID-315M-4	132	1485	216	7.0	849	2.0	2.2	94.2	95.1	95.6	0.81	0.87	0.89	88
PID-315L1-4	160	1485	261	7.1	1029	2.0	2.2	94.1	95.2	95.8	0.78	0.85	0.89	88
PID-315L2-4	200	1485	322	7.1	1286	2.0	2.2	94.4	95.5	96.0	0.78	0.85	0.90	88
PID-355M-4	250	1490	403	7.1	1602	2.0	2.2	94.2	95.3	96.0	0.86	0.90	0.90	95
PID-355L-4	315	1490	507	7.1	2019	2.0	2.2	94.6	95.7	96.0	0.87	0.90	0.90	95
<b>High-Output Design - Special Frame</b>														
PID-250M2-4	75	1485	125	6.9	482	2.0	2.3	93.8	94.9	95.0	0.78	0.86	0.88	79
PID-280M2-4	110	1485	180	7.0	707	2.0	2.2	93.9	95.0	95.4	0.80	0.88	0.89	80

IEC frame	Output (kW)	Rated Speed (rpm)	Full load current I <sub>R</sub> (A)	Locked rotor current (I <sub>L</sub> /I <sub>R</sub> )	Full load torque T <sub>R</sub> (N.m)	Locked rotor torque (T <sub>L</sub> /T <sub>R</sub> )	Break-down torque (T <sub>B</sub> /T <sub>R</sub> )	415V						Sound power level dB(A)
								% of full load						
								Efficiency η (%)			Power factor (cosφ)			
								50	75	100	50	75	100	
<b>6 Pole-1000 rpm-50Hz</b>														
PID-132S-6	3	970	6.6	6.8	29.5	2.0	2.1	83.9	85.4	85.6	0.59	0.71	0.74	69
PID-132M1-6	4	970	8.7	6.8	39.4	2.0	2.1	86.3	86.9	86.8	0.61	0.73	0.74	69
PID-132M2-6	5.5	970	11.6	7.0	54.1	2.0	2.1	86.9	87.9	88.0	0.61	0.73	0.75	69
PID-160M-6	7.5	970	14.8	7.0	73.8	2.0	2.1	87.4	88.9	89.1	0.60	0.73	0.79	73
PID-160L-6	11	970	21.2	7.2	108	2.0	2.1	89.2	90.0	90.3	0.64	0.75	0.80	73
PID-180L-6	15	975	28.2	7.3	147	2.0	2.1	89.5	90.7	91.2	0.63	0.75	0.81	73
PID-200L1-6	18.5	980	34.7	7.3	180	2.0	2.1	90.4	91.4	91.7	0.63	0.76	0.81	73
PID-200L2-6	22	980	41.0	7.4	214	2.0	2.1	90.7	91.7	92.2	0.63	0.76	0.81	73
PID-225M-6	30	985	54.1	6.9	291	2.0	2.1	91.8	92.6	92.9	0.69	0.79	0.83	74
PID-250M-6	37	985	65.7	7.1	359	2.0	2.1	92.0	93.0	93.3	0.69	0.79	0.84	76
PID-280S-6	45	985	78.6	7.3	436	2.0	2.0	92.9	93.6	93.7	0.74	0.83	0.85	78
PID-280M-6	55	985	94.6	7.3	533	2.0	2.0	93.2	94.0	94.1	0.73	0.82	0.86	78
PID-315S-6	75	985	131	6.6	727	2.0	2.0	93.0	94.2	94.6	0.68	0.81	0.84	83
PID-315M-6	90	985	155	6.7	873	2.0	2.0	93.5	94.6	94.9	0.69	0.81	0.85	83
PID-315L1-6	110	985	189	6.7	1066	2.0	2.0	93.7	94.8	95.1	0.70	0.81	0.85	83
PID-315L2-6	132	985	224	6.8	1280	2.0	2.0	93.9	94.9	95.4	0.73	0.82	0.86	83
PID-355M1-6	160	990	271	6.8	1543	1.8	2.0	93.8	95.0	95.6	0.75	0.84	0.86	85
PID-355M2-6	200	990	334	6.8	1929	1.8	2.0	94.4	95.4	95.8	0.78	0.85	0.87	85
PID-355L-6	250	990	417	6.8	2412	1.8	2.0	94.6	95.5	95.8	0.81	0.87	0.87	85

IEC frame	Output (kW)	Rated Speed (rpm)	Full load current I <sub>R</sub> (A)	Locked rotor current (I <sub>L</sub> /I <sub>R</sub> )	Full load torque T <sub>R</sub> (N.m)	Locked rotor torque (T <sub>L</sub> /T <sub>R</sub> )	Break-down torque (T <sub>B</sub> /T <sub>R</sub> )	415V						Sound power level dB(A)
								% of full load						
								Efficiency η (%)			Power factor (cosφ)			
								50	75	100	50	75	100	
<b>8 Pole-750 rpm-50Hz</b>														
PID-132S-8	2.2	715	5.3	6.7	29.4	1.8	2.0	80.5	82.0	81.9	0.52	0.65	0.71	64
PID-132M-8	3	715	6.8	6.9	40.1	1.8	2.0	81.6	82.9	83.5	0.51	0.64	0.73	64
PID-160M1-8	4	725	9.0	6.9	52.7	1.9	2.0	83.4	85.0	84.8	0.52	0.66	0.73	68
PID-160M2-8	5.5	725	12.0	6.9	72.4	1.9	2.0	85.7	86.7	86.2	0.55	0.68	0.74	68
PID-160L-8	7.5	725	15.9	6.6	98.8	1.9	2.0	86.5	87.3	87.3	0.55	0.68	0.75	68
PID-180L-8	11	730	23.0	6.6	144	2.0	2.0	87.3	88.5	88.6	0.55	0.68	0.75	70
PID-200L-8	15	735	30.6	6.8	195	2.0	2.0	88.0	89.5	89.6	0.59	0.71	0.76	73
PID-225S-8	18.5	735	37.6	6.8	240	1.9	2.0	88.6	90.1	90.1	0.62	0.73	0.76	73
PID-225M-8	22	735	43.3	7.0	286	1.9	2.0	89.1	90.4	90.6	0.63	0.74	0.78	73
PID-250M-8	30	735	57.9	6.7	390	1.9	2.0	90.6	91.4	91.3	0.62	0.73	0.79	75
PID-280S-8	37	740	71.0	6.7	478	1.9	2.0	90.6	91.7	91.8	0.63	0.74	0.79	76
PID-280M-8	45	740	85.9	6.7	581	1.9	2.0	91.9	92.4	92.2	0.65	0.76	0.79	76
PID-315S-8	55	740	102	6.8	710	1.8	2.0	91.5	92.3	92.5	0.70	0.78	0.81	82
PID-315M-8	75	740	138	6.3	968	1.8	2.0	91.8	92.6	93.1	0.69	0.77	0.81	82
PID-315L1-8	90	740	163	6.4	1161	1.8	2.0	92.3	93.2	93.4	0.69	0.78	0.82	82
PID-315L2-8	110	740	199	6.4	1420	1.8	2.0	92.2	93.3	93.7	0.69	0.78	0.82	82
PID-355M1-8	132	740	238	6.4	1704	1.8	2.0	92.4	93.9	94.0	0.70	0.79	0.82	89
PID-355M2-8	160	740	288	6.4	2065	1.8	2.0	92.6	94.1	94.3	0.70	0.79	0.82	89
PID-355L-8	200	740	354	6.4	2581	1.8	2.0	92.5	94.1	94.6	0.70	0.79	0.83	89

## 17. Installation and Dimensions

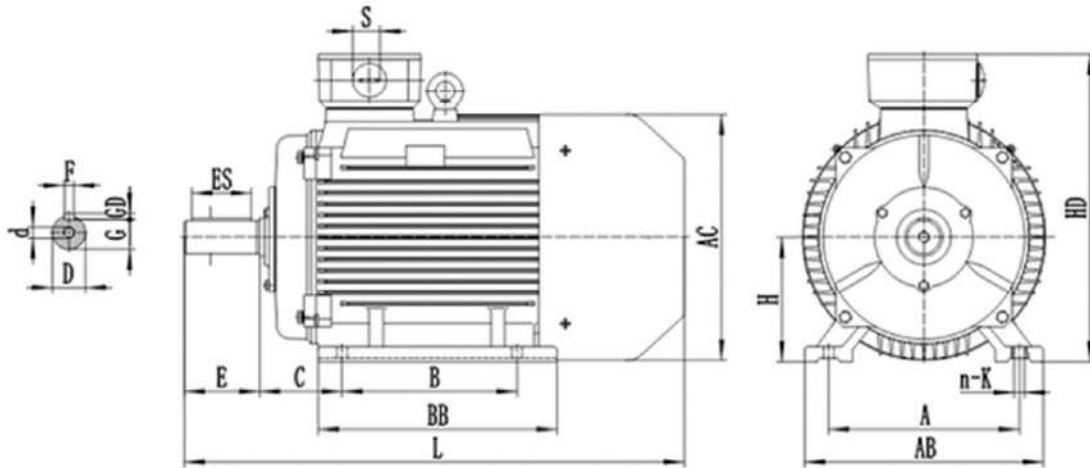

B3 Installation Dimensions(mm)

IEC Frame	Main Dimensions (mm)											Shaft Dimensions (mm)						Bearings		
	L	HD	AC	A	AB	B	BB	C	H	K	S1	ΦD	E	ES	F	G	GD	d	D.E.	N.D.E.
PID-132S	465	335	256	216	262	140	186	89	132	12	M32x1.5	38k6	80	70/60/63	10	33	8	M12	6208	6208
PID-132M	505	335	256	216	262	178	224	89	132	12	M32x1.5	38k6	80	70/60/93	10	33	8	M12	6208	6208
PID-160M	610	405	311	254	314	210	260	108	160	15	M40x1.5	42k6	110	90/80	12	37	8	M16	6309	6309
PID-160L	654	405	311	254	314	254	304	108	160	15	M40x1.5	42k6	110	90/80	12	37	8	M16	6309	6309
PID-180M	682	442	352	279	349	241	311	121	180	15	M40x1.5	48k6	110	100/90/80	14	42.5	9	M16	6311	6311
PID-180L	720	442	352	279	349	279	349	121	180	15	M40x1.5	48k6	110	100/90/80	14	42.5	9	M16	6311	6311
PID-200M/L	782	492	394	318	388	267/305	369	133	200	19	M50x1.5	55m6	110	100/90/80	16	49	10	M20	6312	6312
PID-225S/M-2	815	540	442	356	431	286/311	393	149	225	19	M50x1.5	55m6	110	100/90/100	16	49	10	M20	6313	6313
PID-225S/M-4,6,8	845	540	442	356	431	286/311	393	149	225	19	M50x1.5	60m6	140	125/120/125	18	53	11	M20	6313	6313
PID-250S/M-2	910	608	481	406	484	311/349	445	168	250	24	M63x1.5	60m6	140	125/120/125	18	53	11	M20	6316	6314
PID-250S/M2-2	970	608	481	406	484	311/349	445	168	250	24	M63x1.5	60m6	140	125/120/125	18	53	11	M20	6316	6314
PID-250S/M-4,6,8	910	608	481	406	484	311/349	445	168	250	24	M63x1.5	70m6	140	125/120/125	20	62.5	12	M20	6316	6314
PID-250S/M2-4	970	608	481	406	484	311/349	445	168	250	24	M63x1.5	70m6	140	125/120/125	20	62.5	12	M20	6316	6314
PID-280S/M-2	1023	665	543	457	544	368/419	536	190	280	24	M63x1.5	65m6	140	125/120/125	18	58	11	M20	6317	6314
PID-280S/M2-2	1083	665	543	457	544	368/419	576	190	280	24	M63x1.5	65m6	140	125/120/125	18	58	11	M20	6317	6314
PID-280S/M-4,6,8	1053	665	543	457	544	368/419	536	190	280	24	M63x1.5	80m6	170	140/150/160	22	71	14	M20	6317	6317
PID-280S/M2-4	1113	665	543	457	544	368/419	576	190	280	24	M63x1.5	80m6	170	140/150/160	22	71	14	M20	6317	6317
PID-315S/M/L-2	1310	845	616	508	628	406/457/508	680	216	315	28	M63x1.5	65m6	140	125/120/125	18	58	11	M20	6317	6317
PID-315S/M/L-4,6,8	1340	845	616	508	628	406/457/508	680	216	315	28	M63x1.5	85m6	170	150/160	22	76	14	M20	6319	6319
PID-355M/L-2	1540	1000	694	610	726	560/630	750	254	355	28	M63x1.5	75m6	140	125/120/125	20	67.5	12	M20	6319	6319
PID-355M/L-4,6,8	1580	1000	694	610	726	560/630	750	254	355	28	M63x1.5	100m6	210	180/200	28	90	16	M24	6322	6322

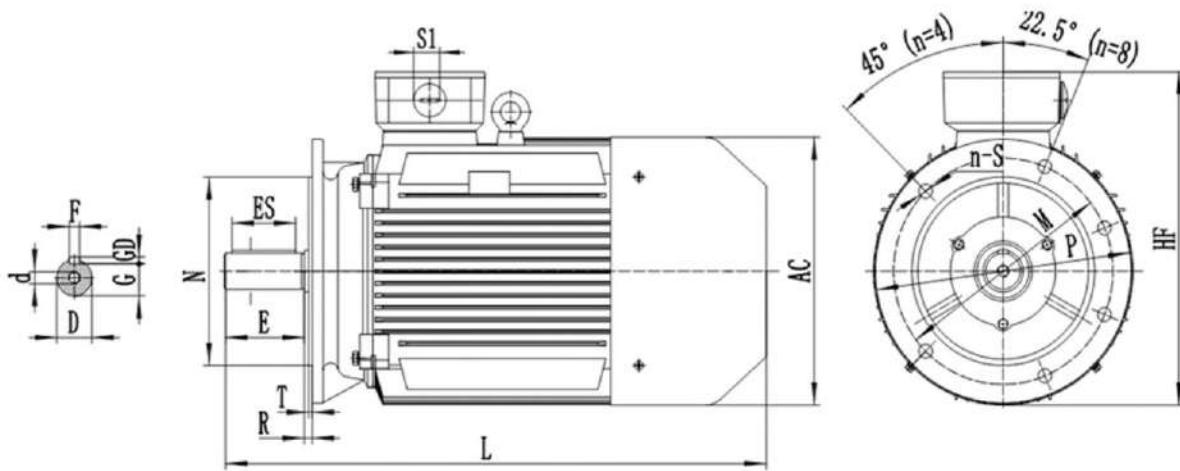

B5 Installation Dimensions(mm)

IEC Frame	Main Dimensions (mm)											Shaft Dimensions (mm)							Bearings	
	L	HD	AC	A	AB	B	BB	C	H	K	S1	ΦD	E	ES	F	G	GD	d	D.E.	N.D.E.
PID-132S	465	353	256	300	265	230	0	4	14.5	4	M32x1.5	38k6	80	60	10	33	8	M12	6208	6208
PID-132M	505	353	256	300	265	230	0	4	14.5	4	M32x1.5	38k6	80	60	10	33	8	M12	6208	6208
PID-160M	610	420	311	350	300	250	0	5	18.5	4	M40x1.5	42k6	110	90	12	37	8	M16	6309	6309
PID-160L	654	420	311	350	300	250	0	5	18.5	4	M40x1.5	42k6	110	90	12	37	8	M16	6309	6309
PID-180M	682	438	352	350	300	250	0	5	18.5	4	M40x1.5	48k6	110	90	14	42.5	9	M16	6311	6311
PID-180L	720	438	352	350	300	250	0	5	18.5	4	M40x1.5	48k6	110	90	14	42.5	9	M16	6311	6311
PID-200M/L	782	492	394	400	350	300	0	5	18.5	4	M50x1.5	55m6	110	90	16	49	10	M20	6312	6312
PID-225S/M-2	815	540	442	450	400	350	0	5	18.5	8	M50x1.5	55m6	110	90	16	49	10	M20	6313	6313
PID-225S/M-4,6,8	845	540	442	450	400	350	0	5	18.5	8	M50x1.5	60m6	140	120	18	53	11	M20	6313	6313
PID-250S/M-2	910	633	481	550	500	450	0	5	18.5	8	M63x1.5	60m6	140	120	18	53	11	M20	6316	6314
PID-250S/M2-2	970	633	481	550	500	450	0	5	18.5	8	M63x1.5	60m6	140	120	18	53	11	M20	6316	6314
PID-250S/M-4,6,8	910	633	481	550	500	450	0	5	18.5	8	M63x1.5	70m6	140	120	20	62.5	12	M20	6316	6314
PID-250S/M2-4	970	633	481	550	500	450	0	5	18.5	8	M63x1.5	70m6	140	120	20	62.5	12	M20	6316	6314
PID-280S/M-2	1023	660	543	550	500	450	0	5	18.5	8	M63x1.5	65m6	140	120	18	58	11	M20	6317	6314
PID-280S/M2-2	1083	660	543	550	500	450	0	5	18.5	8	M63x1.5	65m6	140	120	18	58	11	M20	6317	6314
PID-280S/M-4,6,8	1053	660	543	550	500	450	0	5	18.5	8	M63x1.5	80m6	170	150	22	71	14	M20	6317	6317
PID-280S/M2-4	1113	660	543	550	500	450	0	5	18.5	8	M63x1.5	80m6	170	150	22	71	14	M20	6317	6317

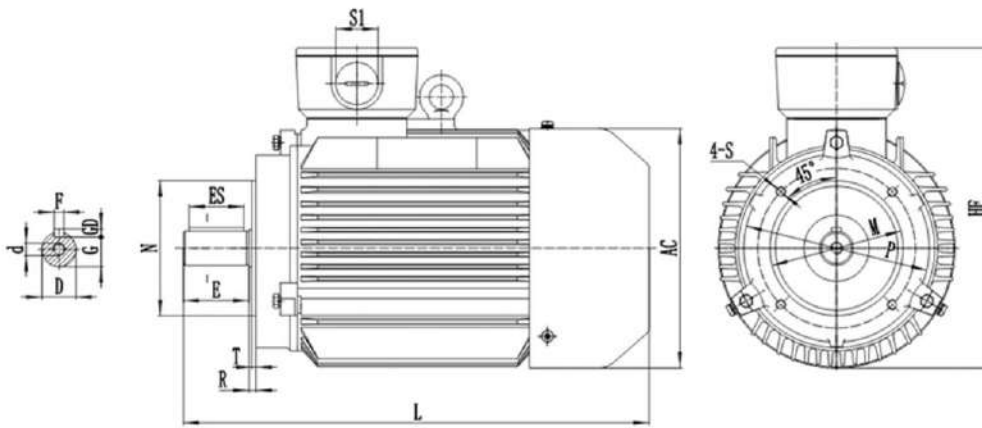

B14 Installation Dimensions(mm)

IEC Frame	Main Dimensions (mm)											Shaft Dimensions (mm)						Bearings		
	L	HD	AC	A	AB	B	BB	C	H	K	S1	ΦD	E	ES	F	G	GD	d	D.E.	N.D.E.
PID-132S	465	332	256	200	165	130	0	3.5	M10	4	M32x1.5	38k6	80	60	10	33	8	M12	6208	6208
PID-132M	505	332	256	200	165	130	0	3.5	M10	4	M32x1.5	38k6	80	60	10	33	8	M12	6208	6208
PID-160M	610	400	311	250	215	180	0	4	M12	4	M40x1.5	42k6	110	90	12	37	8	M16	6309	6309
PID-160L	654	400	311	250	215	180	0	4	M12	4	M40x1.5	42k6	110	90	12	37	8	M16	6309	6309

## 18. Warranty & Scope of Supply

All PERDURUS motor ranges are supplied with a manufacturer’s warranty covering defects in materials and workmanship.

The standard warranty period is 36 months from date of shipment, unless otherwise agreed in writing. Warranty validity is conditional upon installation, operation, and maintenance being carried out in accordance with applicable standards and PERDURUS recommendations.

The scope of supply includes the motor as defined by the PERDURUS standard build or the confirmed order specification. Installation, commissioning, wiring, and maintenance services are excluded unless expressly agreed in writing.

Full warranty terms and conditions are available upon request.





Persistence in Engineering, Durability in Performance



☎ **03 9279 2886**

🌐 [www.perdurus.com.au](http://www.perdurus.com.au)

✉ [info@perdurus.com.au](mailto:info@perdurus.com.au)

📍 12 Venture Ct, Dandenong South VIC 3175, Australia

